

NOTES: (UNLESS OTHERWISE SPECIFIED)

1. Interface according to IEC:169-16.
2. With a protective cap.
3. Part must be packaged to avoid any damages during transportation.
4. After crimping dimension should be AF/SW 3.25

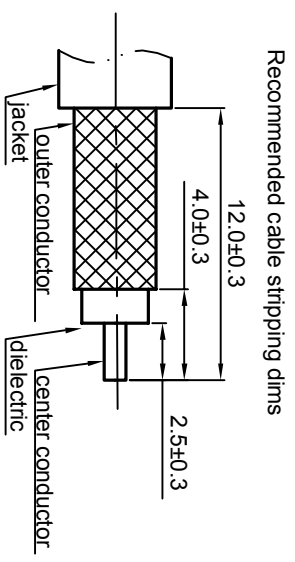
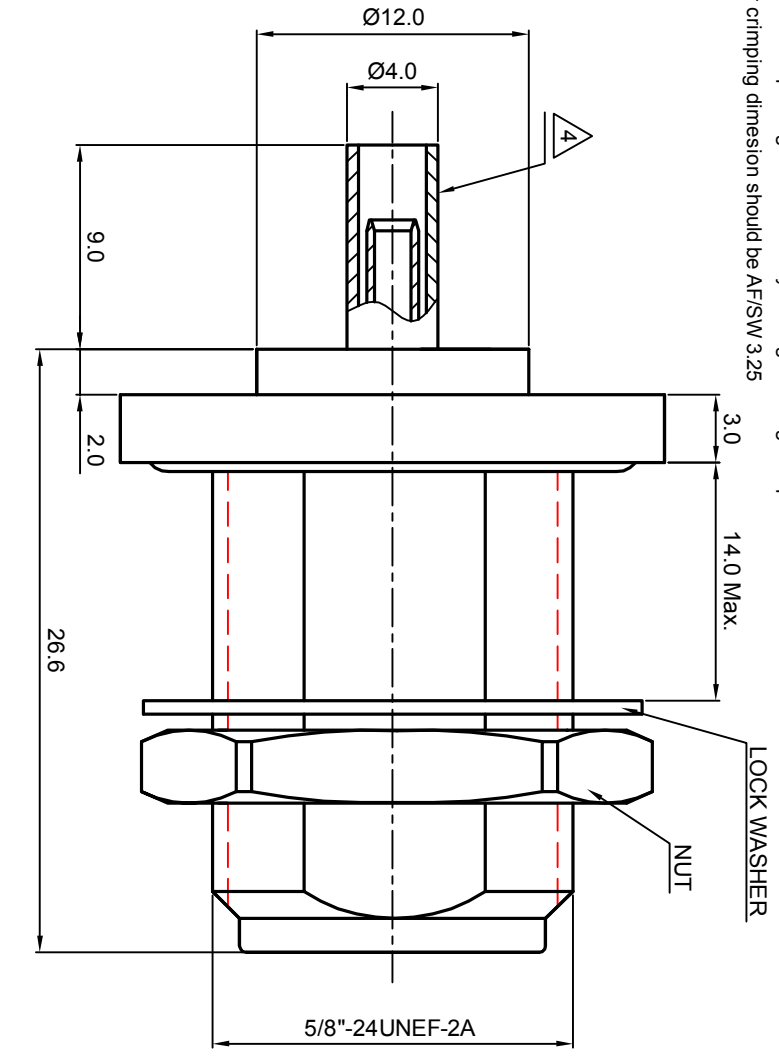

Recommended cable stripping dims

REV.	DESCRIPTION	APPROVED	DATE	ECN
A	REL TO PRODUCTION	Johnny	21 Jul 08	ECN_08_034

MATERIAL		SEE BOM		THIRD ANGLE PROJECTION		TITLE	
FINISH		SEE BOM		GENERAL ECCENTRICITY		N, JACK, FLANGE	
TOLERANCES		Opface X ±1 1place X ±0.1 2place XX ±0.05 Angle ±5°		Remove burrs and sharp edges -0.1 +0.1		DWG NO. 5058.N.JSC.06.133	
SURFACE		VOLUME		DRAWN BY		SCALE	
XXX - measuring point for plating				Colin		3:1	
Plating part to be touched by gloves				CHECKED BY		DO NOT SCALE DRAWING	
Dimension apply before plating				APPROVED BY		SIZE	
Dimension apply before plating						A4	
Dimension apply before plating						SHEET	
Dimension apply before plating						1 of 1	
Dimension apply before plating						REV.	
Dimension apply before plating						A	

