

NOTES: (UNLESS OTHERWISE SPECIFIED)

1. Mating according to MIL-STD-348A.
2. Part must be packaged to avoid any damages during transportation.
3. After crimping dimension should be AF/SW 2.65.

REV.	DESCRIPTION	APPROVED	DATE	ECN

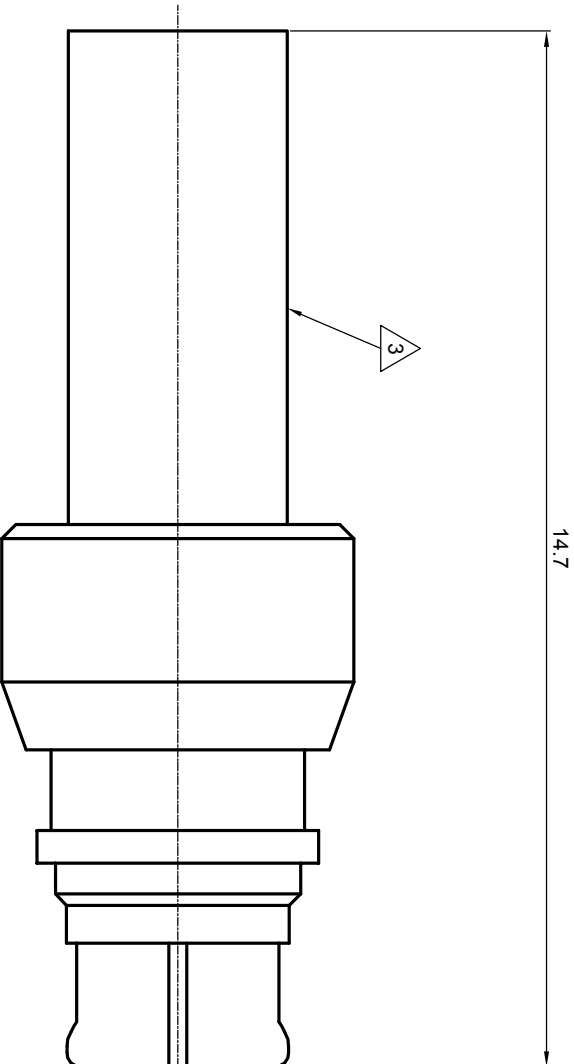

recommended cable stripping dirms

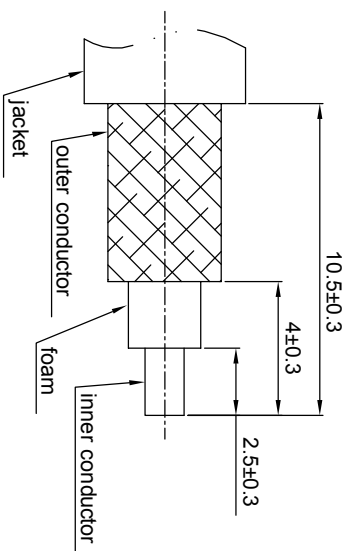

1.6

MATERIAL		SEE BOM		TOLERANCES		THIRD ANGLE PROJECTION		TITLE	
FINISH		SEE BOM		Optical X ±1 1place X ±0.1 2place .XX ±0.05 Angle ±5°					
SURFACE		SEE BOM		Remove burrs and sharp edges		DRAWN BY		SMP, Jack, cable	
VOLUME		SEE BOM				CHECKED BY		DWG NO.	
SURFACE		SEE BOM		Plating part to be touched by gloves		APPROVED BY		5115.SMP.JSC.05.111	
VOLUME		SEE BOM		Dimension apply before plating		NAME		SCALE	
SURFACE		SEE BOM		XXX - measuring point for plating		DATE		DO NOT SCALE DRAWING	
VOLUME		SEE BOM		NOTICE: Those drawings and specifications are the property of ZEETEQ CORPORATION and used only for the specify purpose authorised by ZEETEQ		Joy Zhou 12Nov07		SIZE	
SURFACE		SEE BOM		Angle		12Nov07		SHEET	
VOLUME		SEE BOM		±5°		12Nov07		1 of 1	