

NOTES: (UNLESS OTHERWISE SPECIFIED)

1. Mating according to MIL-STD-348A.
2. Part must be packaged to avoid any damages during transportation.
3. After crimping dimension should be AF/SW 3.25.

REV.	DESCRIPTION	APPROVED	DATE	ECN

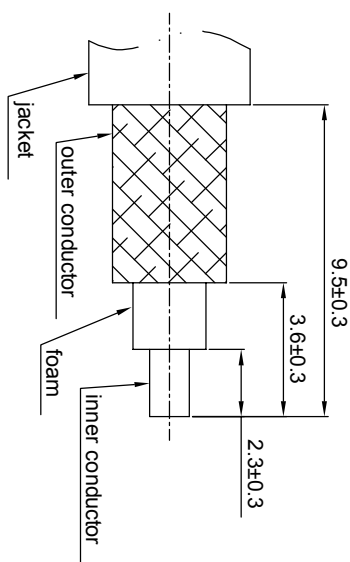
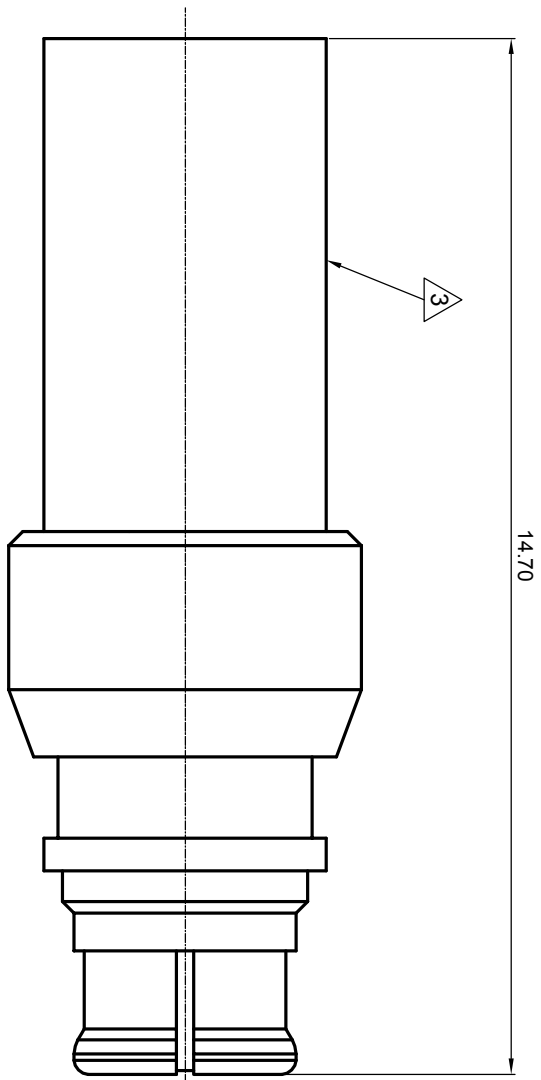

recommended cable stripping dirms

1.6

MATERIAL		SEE BOM		TOLERANCES		THIRD ANGLE PROJECTION		TITLE	
FINISH		SEE BOM		Optical X ±1 1place X ±0.1 2place .XX ±0.05 Angle ±5°					
Plating part to be touched by gloves		Remove burrs and sharp edges				GENERAL ECCENTRICITY		SMP, Jack, cable	
Dimension apply before plating		XXX - measuring point for plating		DRAWN BY		NAME		DATE	
SURFACE		VOLUME		CHECKED BY		APPROVED BY		DWG. NO.	
NOTICE: Those drawings and specifications are the property of ZEETEQ CORPORATION and used only for the specify purpose authorised by ZEETEQ		SCALE		DO NOT SCALE DRAWING		SIZE		SHEET	
10:1		A4		1 of 1		5117.SMP.JSC.07.111		REV. S1	