

NOTES: (UNLESS OTHERWISE SPECIFIED)

1. The interface comply with MIL-STD-348A.

RECOMMENDED CABLE STRIPPING DIMENSIONS

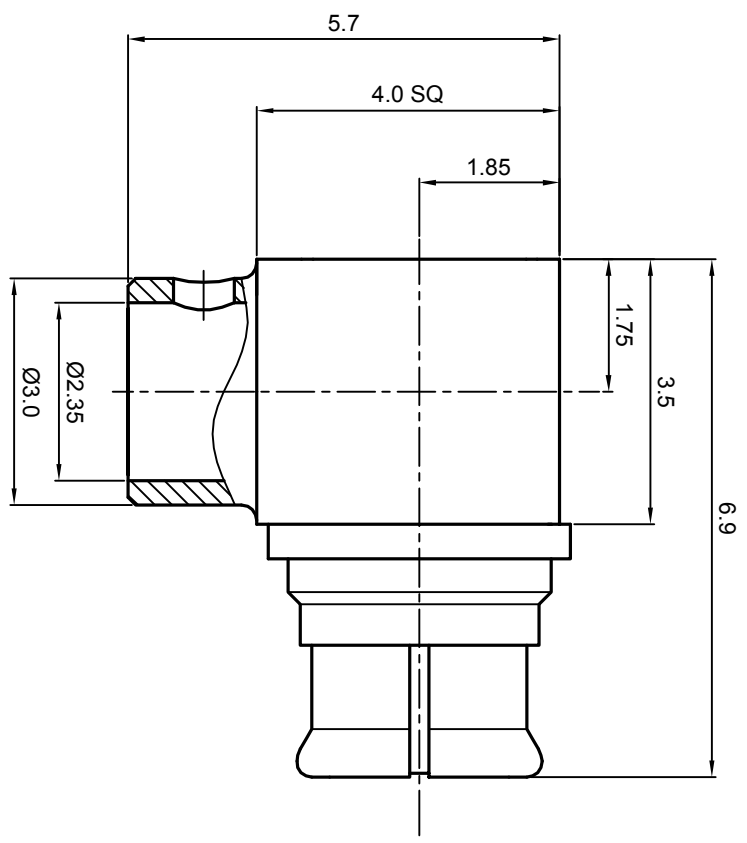
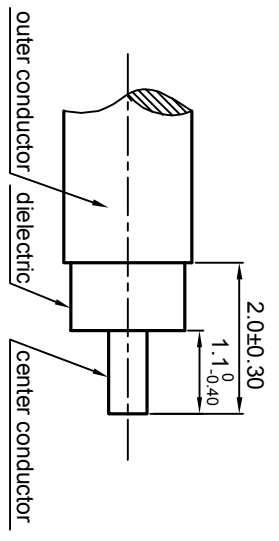

REV.	DESCRIPTION	APPROVED	DATE	EON
A	REL. TO PRODUCTION	Johnny	25Dec07	

MATERIAL SEE BOM FOR DETAILS		TOLERANCES Oplace X ±1 1place X ±0.1 2place XX ±0.05 Angle ±5°		THIRD ANGLE PROJECTION 		TITLE SMP, JACK, CABLE	
FINISH SEE BOM FOR DETAILS		Remove burrs and sharp edges 		GENERAL ECCENTRICITY <input type="checkbox"/> 0.06		DWG. NO. 5112.SMP.JRC.02.111	
Plating part to be touched by gloves Dimension apply before plating XXX - measuring point for plating		DRAWN BY Danny 05Nov07		NAME Danny DATE 05Nov07		SCALE 10:1	
SURFACE		CHECKED BY Colin 25Dec07		APPROVED BY Johnny 25Dec07		DO NOT SCALE DRAWING	
VOLUME		NOTICE: Those drawings and specifications are the property of ZEETEQ CORPORATION and used only for the specify purpose authorised by ZEETEQ		SIZE A4		SHEET 1 of 1	

