

NOTES: (UNLESS OTHERWISE SPECIFIED)

- Interface comply with IEC 169-15.
- Part must be packaged to avoid any damaged during transportation.

After crimping dimension should be A/F/SW 5.41.

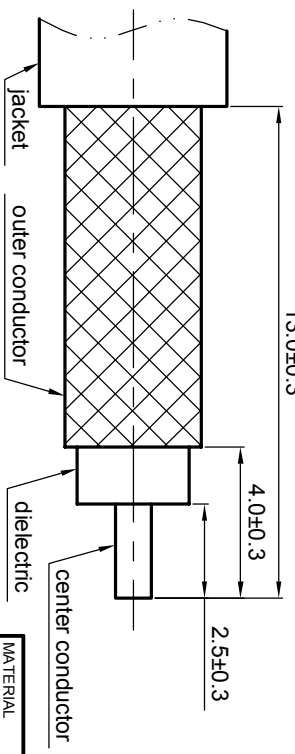
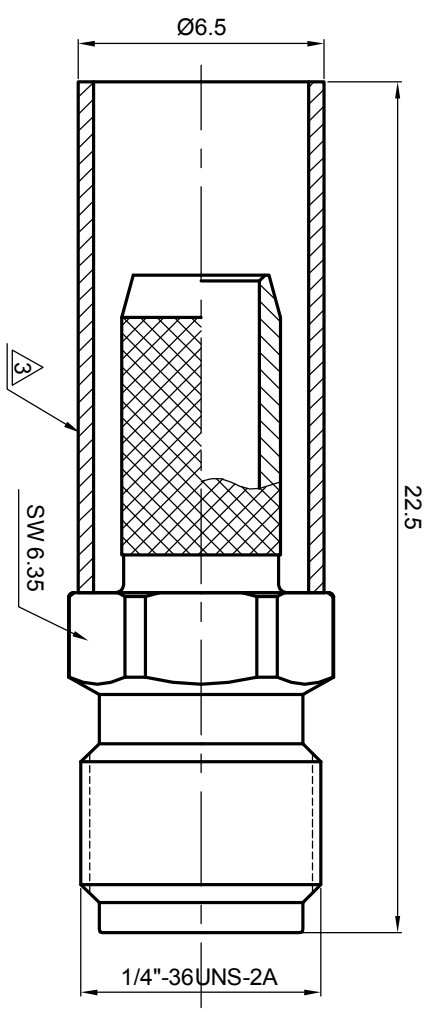

MATERIAL		SEE BOM OF DETAILS		TOLERANCES		THIRD ANGLE PROJECTION	
SEE BOM OF DETAILS		SEE BOM OF DETAILS		OpPlace X ±1 1place X ±0.1 2place .XX ±0.05 Angle ±5°		GENERAL ECCENTRICITY <input checked="" type="checkbox"/> 0.06	
FINISH		SEE BOM OF DETAILS		Remove burrs and sharp edges		DRAWN BY NAME DATE Billy.Lei 11 Oct 07	
Plating part to be touched by gloves				-0.2 +0.2		CHECKED BY APPROVED BY	
SURFACE		VOLUME		NOTICE: Those drawings and specifications are the property of ZEETEQ CORPORATION and used only for the specify purpose authorised by ZEETEQ.			

				TITLE	
SMA, Jack, cable				5162.SMA.JSC.09.111	
DWG NO.		5162.SMA.JSC.09.111		REV. S1	
SCALE		5:1		SHEET 1 OF 1	
DO NOT SCALE DRAWING		SIZE A4			

REV.	DESCRIPTION	APPROVED	DATE	EON