

1

2

3

4

5

6

NOTES: (UNLESS OTHERWISE SPECIFIED)

- 1. Interface comply with IEC 169-15.
- 2. Part must be packaged to avoid any damaged during transportation.

REV.	DESCRIPTION	APPROVED	DATE	ECN

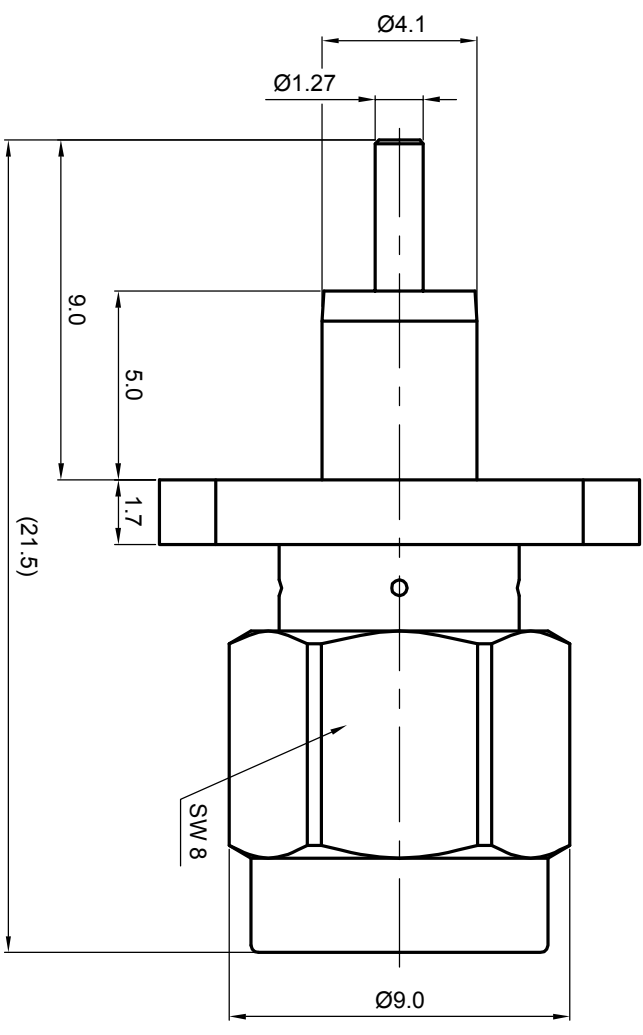
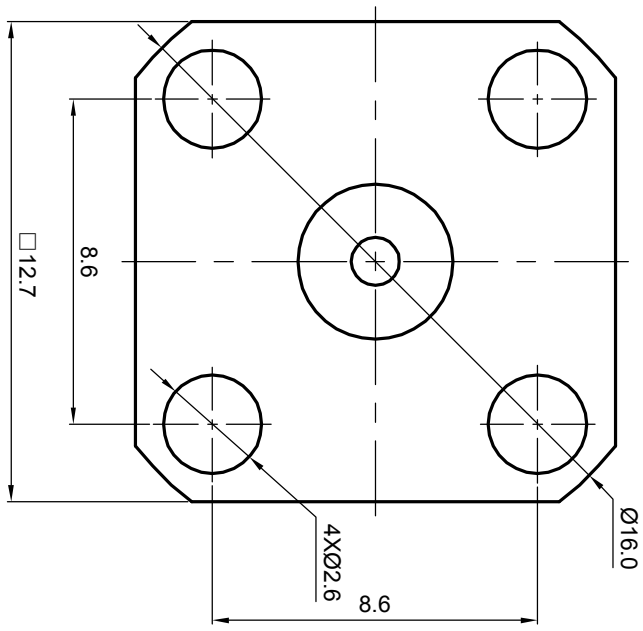

MATERIAL		SEE BOM OF DETAILS		TOLERANCES		THIRD ANGLE PROJECTION		TITLE	
SEE BOM OF DETAILS		SEE BOM OF DETAILS		Opface X ±1 1place X ±0.1 2place .XX ±0.05 Angle ±5°					
FINISH		SEE BOM OF DETAILS		Remove burrs and sharp edges		GENERAL ECCENTRICITY		DWG NO.	
Plating part to be touched by gloves		SEE BOM OF DETAILS				<input checked="" type="checkbox"/> 0.06		6125.SMA.PSF.00.111	
Dimension apply before plating		SEE BOM OF DETAILS		-0.2 +0.2		DRAWN BY		NAME	
XXX - measuring point for plating		SEE BOM OF DETAILS		-0.2 +0.2		Billy.Lei		DATE	
SURFACE		VOLUME		APPROVED BY		CHECKED BY		27 Dec 07	
NOTICE: Those drawings and specifications are the property of ZEETEQ CORPORATION and used only for the specify purpose authorised by ZEETEQ.		NOTICE: Those drawings and specifications are the property of ZEETEQ CORPORATION and used only for the specify purpose authorised by ZEETEQ.		APPROVED BY		CHECKED BY		DATE	
SCALE		DO NOT SCALE DRAWING		SIZE		SHEET		REV.	
5:1		DO NOT SCALE DRAWING		A4		1 of 1		S1	

1

2

3

4

5

6