

**NOTES: (UNLESS OTHERWISE SPECIFIED)**

1. Interface according to IEC 169-15
2. With a protective cap.
3. Part must be packaged to avoid any damages during transportation.

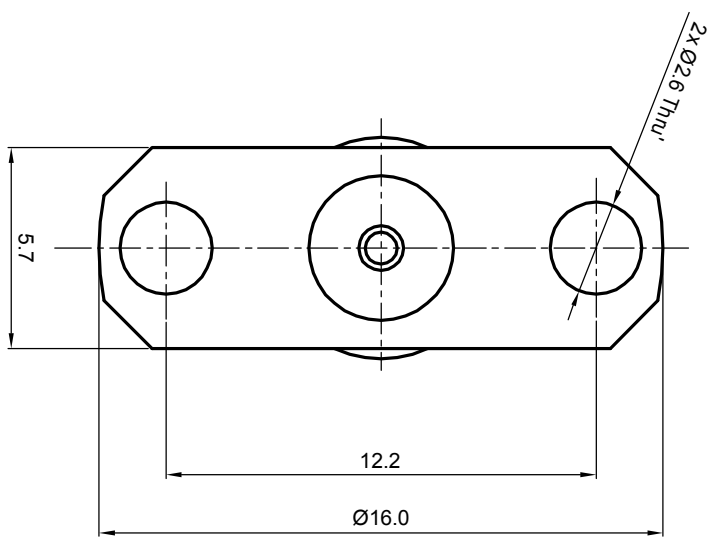
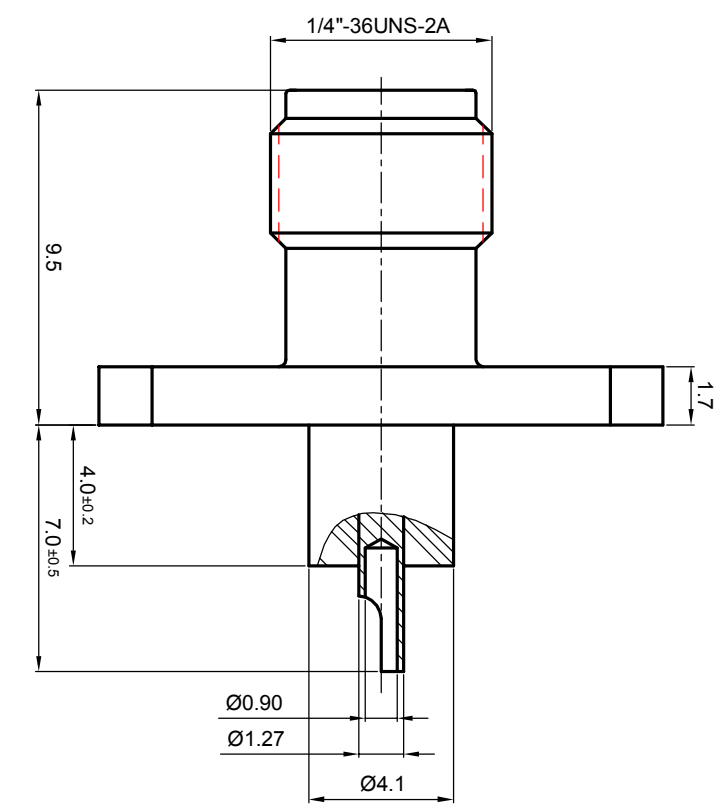

REV.	DESCRIPTION	APPROVED	DATE	ECN
A	Rel to production	Johnny	12Oct07	

MATERIAL <b>SEE BOM</b>		TOLERANCES		THIRD ANGLE PROJECTION		TITLE	
FINISH <b>SEE BOM</b>		Optace X ±1 1place X ±0.1 2place .XX ±0.05 Angle ±5°					
Plating part to be touched by gloves		Remove burrs and sharp edges		GENERAL ECCENTRICITY $Z_{1025}$		SMA, JACK, FLANGE	
Dimension apply before plating				DRAWN BY Collin		DWG. NO. 6034.SMA.JSF.00.110	
XXX - measuring point for plating		APPROVED BY		DATE 15Aug07		REV. A	
SURFACE		VOLUME		SCALE 2:1		DO NOT SCALE DRAWING	
				SIZE A4		SHEET 1 of 1	

**NOTICE:** Those drawings and specifications are the property of ZEETEQ CORPORATION and used only for the specify purpose authorised by ZEETEQ